



LOCAL AREA NETWORKS (LAN)



SERVERS



DATA CENTERS



TELECOM-MUNICATION DEVICES



E-BUSINESS (Servers Farms, ISP/ASP/POP)



INDUSTRIAL PROCESSES



INDUSTRIAL PLCs



ELECTRO-MEDICAL DEVICES



EMERGENCY DEVICES (Lights/Alarms)

# ePOWER 12 MP

100-800 kVA  
three-phase/three-phase



Master Plus 100-800 kVA



## ABSOLUTE PROTECTION

**Master Plus** is an on-line double conversion UPS (VFI SS 111 in accordance with IEC EN 62040-3) with a transformer isolated inverter. **Master Plus** has a compact foot print and high quality output to provide the ultimate power protection for "mission critical" applications: data processing, tele-communications, industrial processes, security and electro-medical systems.

## EASY SOURCE

**Master Plus** technology removes the problems of over sizing upstream power sources, whilst improving load power factors and current harmonics. The UPS features the latest input current absorption techniques including progressive rectifier start-up and the option to reduce battery charging currents. These features make **Master Plus** one of the most generator compatible and environmentally friendly UPS available.

Dimensions (mm)

MP 100 - MP 120  
MP 160 - MP 200

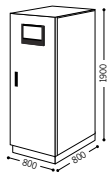

12 MP 300

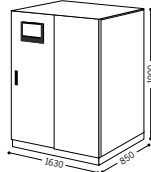

12 MP 400

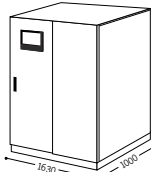

12 MP 500 - 12 MP 600

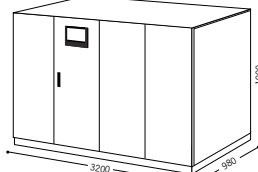

12 MP 800

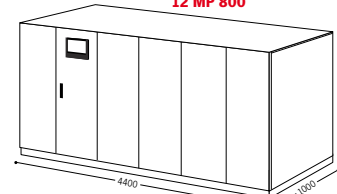

**BATTERY CARE SYSTEM: MAXIMUM LIFETIME POTENTIAL**

Traditionally, when a mains supply is present the UPS charges its batteries. Battery power is used for the inverter should the input supply fail. Efficient battery management and care is therefore essential to the overall performance of the UPS in an emergency.

The Master Plus Battery Care System consists of a range of features designed to provide optimum performance and enhanced operating life:

- Dual level charging regime to optimise recharge currents and lower recharge times
- Temperature compensation and deep discharge protection to reduce overall battery aging
- Charge blocking system to reduce electrolyte consumption and lengthen the life of VRLA batteries
- Predictive battery testing to spot potential battery deterioration and failure

Master Plus is also compatible with different battery technologies: open-vented lead acid and AGM and Gel VRLA, NiCd.

**MAXIMUM RELIABILITY AND AVAILABILITY**

Connect up to 8 units in parallel or N+1 redundancy, even of different power ratings. The UPS continue to operate in parallel even if one of the interconnecting communication cables is disconnected (closed loop).

**OPTIONS**

• **UGS - UPS Group Synchroniser**

Allows 2 or more UPS not in parallel to remain synchronised even during a power failure.

The UGS also enables a RIELLO UPS to be synchronised with an independent power source, even of a different power rating.

• **PSJ - Parallel Systems Joiner**

Connects two UPS groups operating in parallel configurations through a power coupling switch.

The Slave UPS Group is permanently synchronised to the Master group. Should one of the UPS in one of the parallel groups fail, the PSJ will automatically connect the remaining UPS to the other group via an external bypass

**EASE OF INSTALLATION**

Master Plus is compact with a foot print of only 0.64 m<sup>2</sup> for a 200kVA system. Front access to internal assemblies and top panel ventilation make space allocation within confined data processing or plant rooms easy. Master Plus can be placed against a wall as there is no requirement for rear or side panel access for maintenance or ventilation.



**FLEXIBILITY**

Master Plus is suitable for a wide range of applications including IT and the most demanding industrial environments. The UPS is suitable for power capacitive loads such as blade servers, without any reduction in active power, from 0.9 leading to 0.8 lagging. With a broad range of accessories and options, complex configurations and system architectures can be achieved to guarantee maximum power availability and the option to add new UPS without interruption to existing users. Using the Riello UPS Group Synchroniser (UGS) and Parallel Systems Joiner (PSJ) sophisticated inter group parallel and redundant systems can be achieved to provide the highest possible levels of resilience and availability.

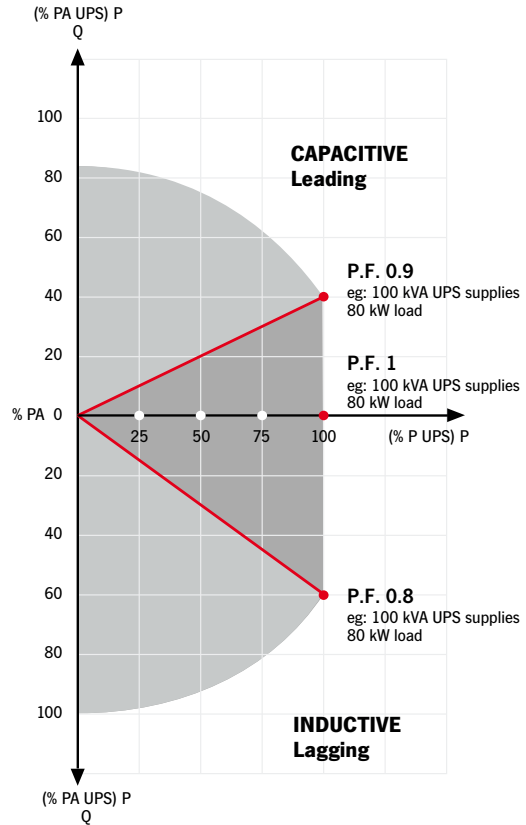

Master Plus 100-800 kVA



## SPECIFIC SOLUTIONS

The UPS can be adapted to your requirements. Please contact TEC to discuss specific applications and options.

## ADVANCED COMMUNICATION

- Compatible with TeleNetGuard for remote maintenance
- Advanced, multi-platform communication for all operating systems and network environments: PowerShield<sup>3</sup> monitoring and shut-down software included, for Windows 2008, Vista, 2003, XP; Mac OS X, Linux, Novell and most popular Unix operating systems. The UPS is supplied with a cable for direct connection to the PC (Plug and Play)

- Double RS232 serial port
- Installation slot for an Emergency Power Off (EPO) interface to allow the UPS to be switched off remotely in an emergency.
- Generator interface: enables desynchronisation of the UPS output from a generator supply which may be subject to phase and frequency variations. The interface also enables more economic use of the battery charger.

1. Parallel configuration of up to 8 units with separate batteries

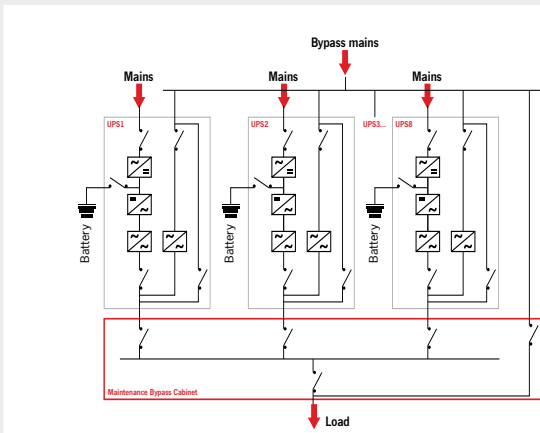

2. Parallel configuration of up to 8 units with a common batteries

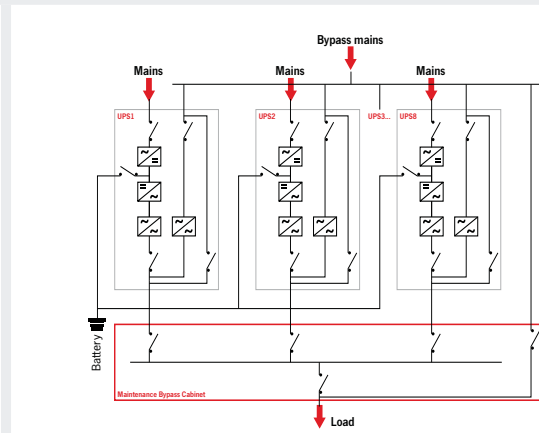

3. Dynamic dual bus configuration

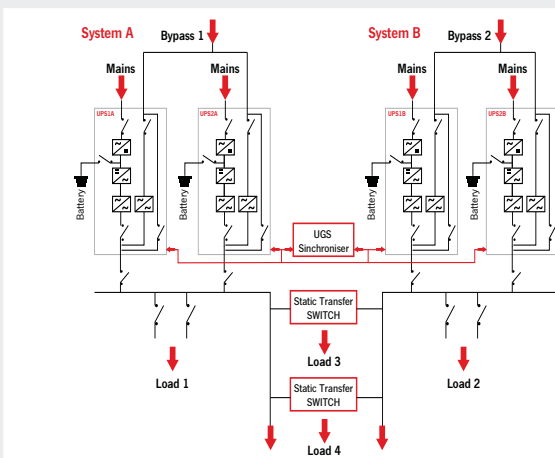

4. Dual bus system configuration

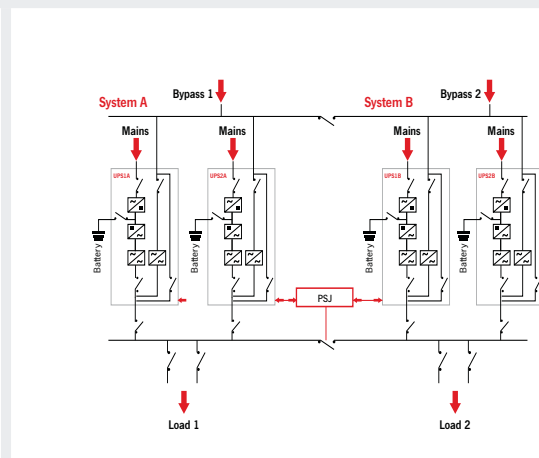

Master Plus 100-800 kVA



MODELS	MP 100	MP 120	MP 160	MP 200
POWER (kVA)	100	120	160	200
<b>INPUT</b>				
Nominal voltage	380 - 400 - 415 Vac three-phase			
Voltage tolerance	400 V + 20% / - 25%			
Frequency	45 ÷ 65 Hz			
Soft start	0 ÷ 100% in 30" (selectable)			
Permitted frequency tolerance	± 2% (selectable from ± 1% to ± 5% from the front panel)			
Standard features	Back Feed protection; separable bypass line			
<b>BATTERIES</b>				
Type	Lead, flooded and VRLA AGM / GEL; NiCd			
AC ripple	< 1%			
Temperature compensation	-0.5 Vx°C			
Typical charging current	0.2 x C10			
<b>OUTPUT</b>				
Rated power (kVA)	100	120	160	200
Active power (kW)	80	96	128	160
Number of phases	3 + N			
Nominal voltage	380 - 400 - 415 Vac three-phase + N			
Static stability	± 1%			
Dynamic stability	± 5% in 10 ms			
Voltage distortion	< 1% with linear load / < 3% with no-linear load			
Crest factor (I <sub>peak</sub> /I <sub>rms</sub> )	3:1			
Frequency stability on battery mode	0.05%			
Frequency	50/60 Hz (selectable)			
Overload	110% for 60'; 125% for 10'; 150% for 1'			
<b>ENVIRONMENTAL</b>				
Weight (kg)	640	650	770	810
Dimensions (HxWxD) (mm)	1900 x 800 x 800			
Remote signalling	Voltage-free contacts			
Remote commands	EPO and bypass			
Communication	double RS232 + remote contacts + 2 communication interface slots			
Operating temperature	0°C ÷ +40°C			
Relative humidity	< 95% non condensing			
Colour	Light grey RAL 7035			
Noise	63 ÷ 68 dBA at 1 m			
Protection rating	IP20			
Efficiency Smart Mode	Up to 98%			
Compliance	European Directives: L V 2006/95/CE Low voltage directive EMC 2004/108/EC Electromagnetic compatibility directive Standards: Safety IEC EN 62040-1; EMC IEC EN 62040-2 C2 Classification according to IEC 62040-3 (Voltage Frequency Independent) VFI - SS - 111			

MODELS	12 MP 300	12 MP 400	12 MP 500	12 MP 600	12 MP 800
POWER (kVA)	300	400	500	600	800
<b>INPUT</b>					
Nominal voltage	380 - 400 - 415 Vac three-phase				
Voltage tolerance	400 V + 20% /- 25%		400 V ± 20%		
Frequency	45 ÷ 65 Hz				
Power factor	> 0.95 in HC version		> 0.93 in HC version		
Current distortion	< 3% in HC version				
Soft start	0 ÷ 100% in 30'' (selectable)				
Permitted frequency tolerance	± 2% (selectable from ± 1% to ± 5% from the front panel)				
Standard features	Back Feed protection; separable bypass line				
<b>BATTERIES</b>					
Type	Lead, flooded and VRLA AGM / GEL; NiCd				
AC ripple	< 1%				
Temperature compensation	-0.5 Vx°C				
Typical charging current	0.2 x C10				
<b>OUTPUT</b>					
Rated power (kVA)	300	400	500	600	800
Active power (kW)	240	320	400	480	640
Number of phases	3 + N				
Nominal voltage	380 - 400 - 415 Vac three-phase + N				
Static stability	± 1%				
Dynamic stability	± 5% in 10 ms				
Voltage distortion	< 1% with linear load / < 3% with no-linear load				
Crest factor (I <sub>peak</sub> /I <sub>rms</sub> )	3:1				
Frequency stability on battery mode	0.05%				
Frequency	50 or 60 Hz (selectable)				
Overload	110% for 60'; 125% for 10'; 150% for 1'				
<b>ENVIRONMENTAL</b>					
Weight (kg)	2200	2600	3600	4000	5300
Dimensions (HxWxD) (mm)	1900 x 1630 x 850	1900 x 1630 x 1000	1900 x 3200 x 980		1900 x 4400 x 1000
Remote signalling	Voltage-free contacts				
Remote commands	EPO and bypass				
Communication	double RS232 + remote contacts + 2 communication interface slots				
Operating temperature	0°C ÷ +40°C				
Relative humidity	< 95% non condensing				
Colour	Light grey RAL 7035				
Noise	< 70 dBA at 1 m		< 77 dBA at 1 m		< 80 dBA at 1 m
Protection rating	IP20				
Efficiency Smart Mode	Up to 98%				
Compliance	European Directives: L V 2006/95/CE Low voltage directive EMC 2004/108/EC Electromagnetic compatibility directive Standards: Safety IEC EN 62040-1; EMC IEC EN 62040-2 C2 Classification according to IEC 62040-3 (Voltage Frequency Independent) VFI - SS - 111				

**OPTIONS**

Isolation transformer module
UPS Group Synchroniser (see UGS)
Hot connection device (see PSJ)
Interface for generator
Closed Loop parallel kit option (to be ordered with the UPS)
Empty or full battery cabinets for prolonged runtime



Master Plus 100-800 kVA

<b>BATTERY BOX MODELS</b>	<b>BB 396-J8</b> <b>BB 396-J9</b> <b>BB 396-K1</b> <b>BB 396-K2</b>	<b>BB 480-A0</b>
MP MODELS	MP 100-200	MP 300-400
Dimensions (mm) h x w x d		

<b>ISOLATION TRANSFORMER MODULE</b>	<b>TT 100</b> <b>TT 120</b> <b>TT 160</b>	<b>TT 200</b>	<b>TT 250</b> <b>TT 300</b>
MP MODELS	MP 100-160	MP 200	12 MP 300
Dimensions (mm) h x w x d			

Best Power Equipments India Pvt Ltd, B-68, Sec-65,  
NOIDA, UP, 201301  
[sales@bpeindia.com](mailto:sales@bpeindia.com), 0120-4143464/0120-4143465

